

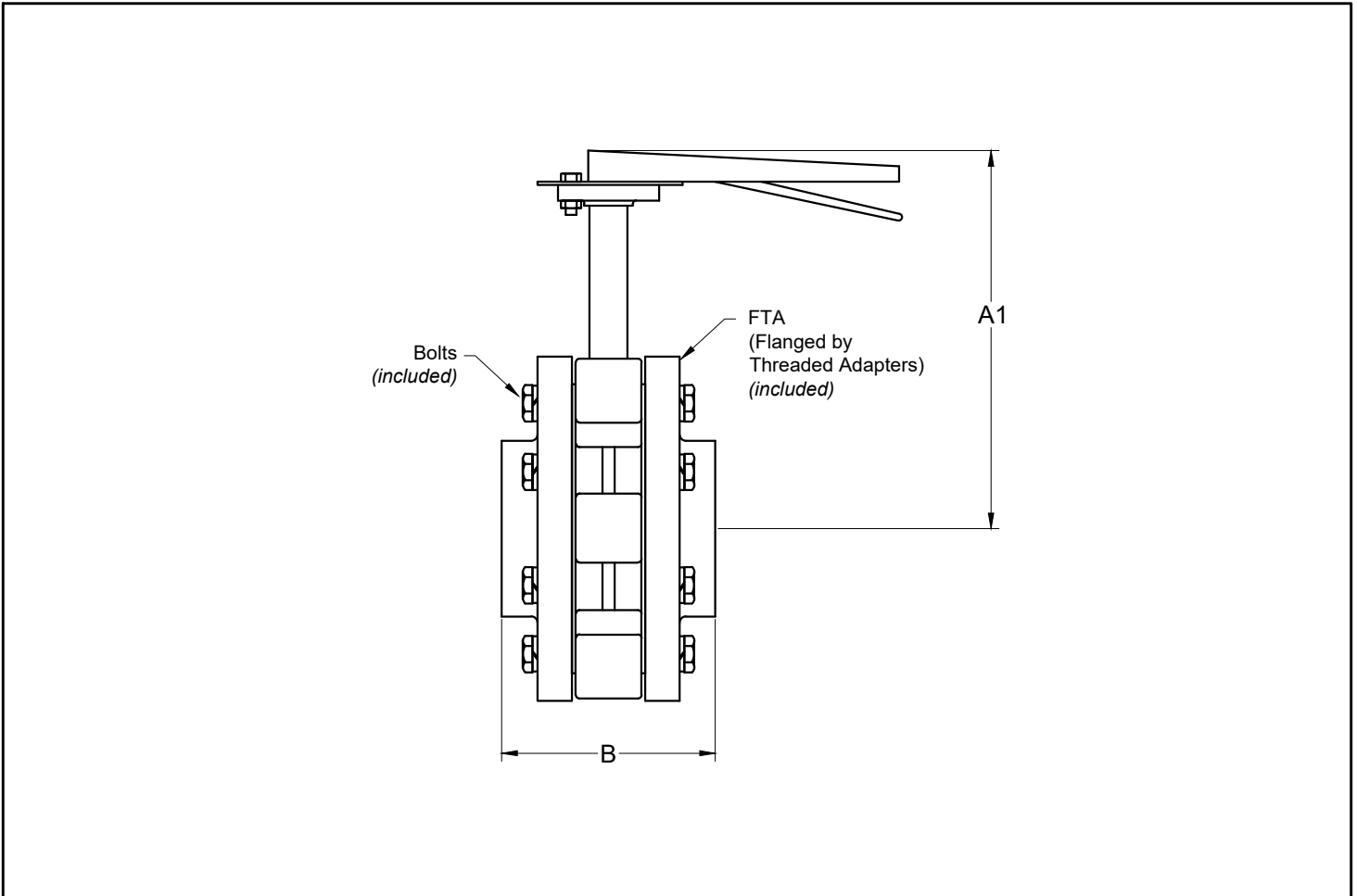

Butterfly Valve Model BVT

Threaded Ends Butterfly Valve

(2½")



DIMENSIONS [inches]						
SIZE	A1	B	Flange	Cv (Full Open)	WT [lbs]	
					Butterfly Valve	FTA ¹
2½	8.2	5.4	FTA - 250	220	10.7	15.5

Note: ¹ Weight for 2 Threaded Adapters w/ Hardware

MATERIALS & DESIGN DATA	
VALVE BODY:EPOXY COATED DUCTILE IRON, ASTM A126, CLASS B, 175 PSIG, 250°F
DISK:316 STAINLESS STEEL (CF8M)
SHAFT:410 STAINLESS STEEL
TOP PLATE:STAINLESS STEEL
THREADED ADAPTERS:DUCTILE IRON, ASTM A395, 175 PSIG, 250°F, STANDARD 125# CLASS B FLANGES (ALSO MATE TO 150# FLANGES)

ORDER DATA

Sample Part #: **B V T - 0 2 5 0**

Model _____
 BVT (2½") - Threaded End Butterfly Valve
 w/Top Plate Assy & Handle

Butterfly Valve Size _____
 0250=2½"

PROJECT _____

CONTRACTOR _____

PO/JOB NO. _____

ENGINEER _____

REPRESENTATIVE _____

DATE _____

Please consult the Ordering Guide in the Nexus Valve catalog for complete part number and ordering information.