

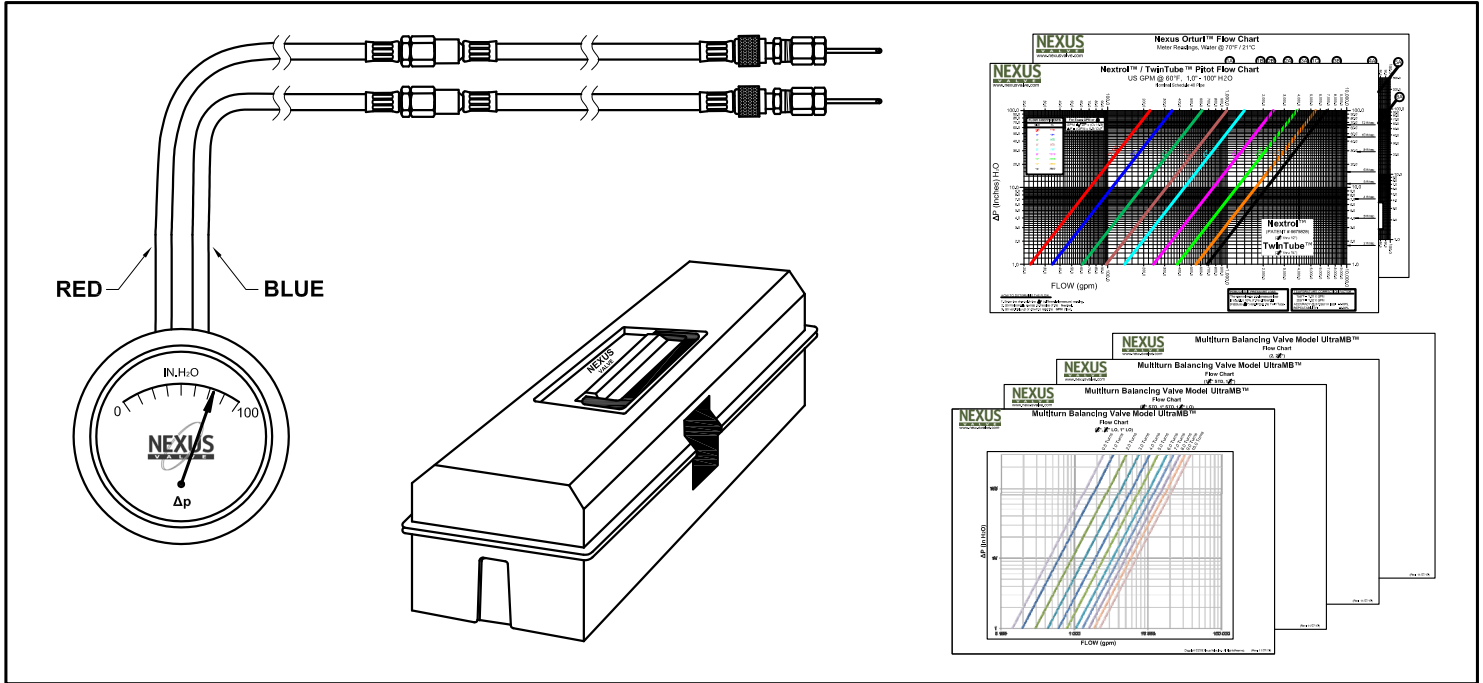

Meter Kit Models

MKM-050, MKM-100, MKM-300

(for Manual Flow Control Valves)



STANDARD MATERIAL SPECIFICATIONS	
GAUGE	<p>BODY, TYPE: ANODIZED ALUMINUM, DIAPHRAGM DIFFERENTIAL PRESSURE</p> <p>LENS: ACRYLIC</p> <p>DIAL, WETTED INTERNALS: 4½" FACE, BUNA-N ELASTOMERS, BRASS & 316 S.S. PARTS</p> <p>CONNECTION: ¼" NPT</p> <p>ACCURACY: 5% FULL SCALE (ASCENDING)</p> <p>RANGES: 0-50 IN.H₂O (MKM-050) 0-100 IN.H₂O (MKM-100) 0-300 IN.H₂O (MKM-300)</p> <p>MAX. OPERATING PRESSURE: 500 PSIG (34.7 bar)</p> <p>OPERATING TEMPERATURE RANGE: 32°F Min. to 180°F Max.</p>
CARRYING CASE	MOLDED PLASTIC, GRAY
HOSES	5 Ft. LONG (RED & BLUE), NITRILE JACKET AND LINER
END FITTINGS	SCHRADER ¼" BRASS COUPLERS AND PT PROBE ADAPTERS
FILTERS	TEST KIT IS PROTECTED WITH 90 MICRON FILTERS TO MINIMIZE PLUGGING WITH SCALE, SAND, ETC. ELEMENTS CAN BE CLEANED OR REPLACED.
CHARTS	LAMINATED SHEETS WITH NEXTROL / ORTURI / TWINTUBE FLOW CHARTS & MKM OPERATING INSTRUCTIONS

ORDER DATA

Part #: MKM-050
MKM-100
MKM-300

PROJECT _____

CONTRACTOR _____

PO/JOB NO. _____

ENGINEER _____

REPRESENTATIVE _____

DATE _____